

REDI CONTROLS

File Literature Number 1144-01-1

Installation Operation & Maintenance Manual

CONTINUOUS REFRIGERANT DEHYDRATOR™

Model: CD-120

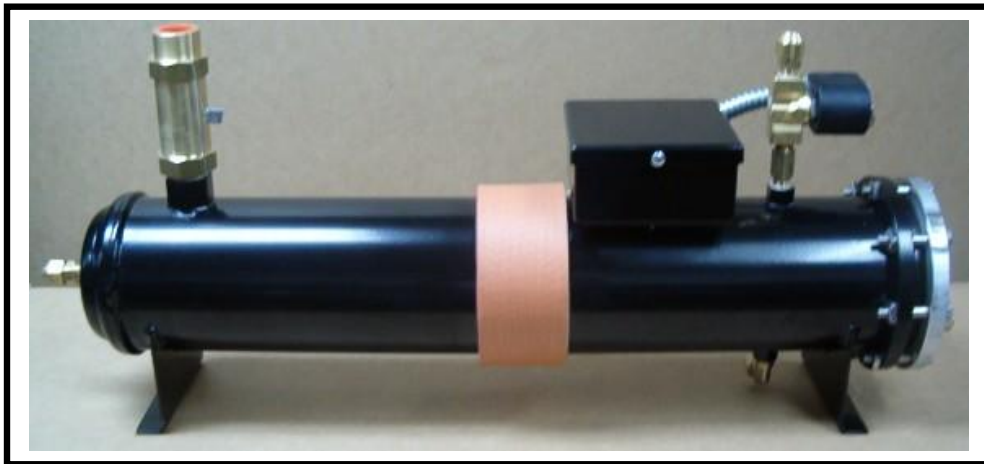

**For use with Refrigerants
R-11, R-123, R-12, R-22, R-134a
(And other similar refrigerants)**

Before You Start

WARNING: Installing or servicing refrigerant support equipment can be hazardous due to system pressures and dangerous voltages. Only qualified service personnel should work on such equipment.

Continuous Dehydrator Specifications

Electrical Power Requirements: 120 VAC, 50/60 Hz, 1-Phase, 15 Amp Fused Circuit
Actual current draw Approximately 4 Amps

Operating Environment: 70°F to 105°F, 5% to 80% relative humidity, non condensing

Storage Environment: 0°F to 120°F, 5% to 80% relative humidity, non condensing

Dimensions (approximate): 12" height x 29" length x 6" depth

Weight (approximate): (without cores) 22 pounds

Shipping weight (approximate): 30 pounds

Dehydrator Shell Factory Pressure Tested At: 350 psig

Dehydrator shell Refrigerant capacity (approximate) 16 lbs.

Average Rate of refrigerant processed (approximate) 12.5 lbs. per cycle
600 lbs. per day
4,200 lbs. per week
218,400 lbs. per year

Contents of the Continuous Dehydrator Installation Kit

NOTE: Most of the fittings required to install the Dehydrator have been anticipated and therefore included in the Installation Kit for your convenience. However, not every item can be anticipated and not will every item furnished be required. In some instances additional fittings, etc. may need to be supplied by the installer.

- (1) 1/2" charging Valve Adapter with copper ferrules and cap
- (1) 5/8" charging Valve Adapter with copper ferrules and cap
- (1) 3/4" to 5/8" Reducing Flare Union (*for use with Charging Valve Adapter if necessary*)
- (1) Spring-Less 3/8" Sweat Check Valve
- (1) 1/4" MPT Access Valve Fitting (*fitting with Schrader valve*)
- (1) 1/4" NPT Pipe Plug
- (1) 1/4" Three Way Tee
- (2) 1/4" Female flare x 3/8" Flare
- (1) 3/8" Flare In-line Strainer
- (1) 3/8" Flare (moisture indicating) Sight Glass
- (10) 3/8" Flare Nuts
- (10) feet of 1/8" adhesive backed Insulation Tape.
- (6) feet of 3/8" ID Armaflex Insulation

Field-Provided Items

Unit mounting hardware (when necessary).
Electrical conduit and wiring materials.
3/8-inch O.D. copper refrigerant tubing.

Preliminary Inspection

Before installing the Continuous Dehydrator, check the data on the nameplate. Make sure the voltage is correct for the application. Visually inspect all components for damage in shipment before installing.

OPERATION OVERVIEW

The Redi Controls **Continuous Refrigerant Dehydrator** is designed to rapidly dehydrate a chiller's refrigeration charge (**flooded evaporator**). Although the primary function of the Continuous Dehydrator is to dehydrate (**remove moisture**) from a refrigerant charge it also **removes acids** and **particulates**.

The **Continuous Refrigerant Dehydrator** operates without the need of either a mechanical or eductor pump. Operation is accomplished via a **patent pending** process utilizing *gravity, heat and pressure*.

HOW THE “CONTINUOUS REFRIGERANT DEHYDRATOR” WORKS

Operation of the *Continuous Refrigerant Dehydrator* is *cyclic and non-stop* as long as power is applied. One complete dehydration cycle comprises a *pre-set timed Fill cycle* and a *pre-set timed refrigerant transfer cycle*. One complete cycle (combined refrigerant *Fill* and *Return* cycle) is approximately 30 minutes in duration.

During the Fill Cycle the 350 watt electric band heater is *de-energized* allowing pressure in the dehydrator to equalize through the *energized* (open) **equalization solenoid valve** to system pressure. During the Fill cycle approximately 12.5 pounds of moisture laden refrigerant flows by gravity through the four (**4**) **Z-48 super high moisture capacity filter-drier cores** and accumulates in Dehydrator shell and is **dehydrated and cleaned in the process**.

At the end of the pre-set timed Fill Cycle the 350 watt heater is **energized** and the *equalization solenoid valve* is **de-energized** (*closed*) for a second pre-set timed period. As heat energy is imparted to the liquid refrigerant, pressure within the dehydrator shell rises. At a pressure differential of about 3 *psig* between the dehydrator and the evaporator refrigerant is forced to flow from the dehydrator shell back into the evaporator.

At the conclusion of the timed refrigerant transfer period the dehydrator enters another Fill cycle wherein the process repeats itself.

It should be noted that the Continuous Refrigerant Dehydrator processes and dehydrates approximately **4,200 pounds of refrigerant per week**. This is a lot of refrigerant. Therefore, if the refrigerant charge is **excessively wet** it won't take long for the filter-drier cores to become saturated, even high moisture capacity cores.

Therefore, initially the cores may require frequent change-out to return the refrigerant charge to proper dry state.

OPERATING PARAMETERS

- 1) **Drier (wet) refrigerant Fill Cycle**: Non-adjustable 20 minute (approximate) pre-set cycle.
- 2) **Drier (dehydrated) Refrigerant Return Cycle**: Non-adjustable 10 minute (approximate) pre-set cycle

INSTALLATION

LOCATION

The *Continuous Refrigerant Dehydrator* is provided with an integral mounting base designed to set **directly on the floor** as close to the refrigerant pick-up point on the evaporator as possible (typically the refrigerant charging valve). The entire **Dehydrator shell** should be lower than the refrigerant level in the evaporator. However, to be minimally effective **at least half** of the Dehydrator shell **must be below the refrigerant level**.

PLUMBING THE DEHYDRATOR

Two different size brass **valve adapters and copper ferrules** are provided in the installation kit for connection to the chiller's charging valve. The valve adapter facilitates connection of the Dehydrator's *Fill Line* to the charging valve without affecting charging valve access. Choose the appropriate size valve adaptor and copper ferrule that fits charging valve.

NOTE: The valve adaptors have a pair of opposing ¼" FNPT ports. Choose the most convenient port for your application and plug the other port using a ¼" pipe plug from the installation kit. **Also, be sure to use the appropriate copper ferrules.**

FILL LINE

- 1) From the installation kit select the appropriate *valve adapter* and *copper ferrule* that fits the chiller's refrigerant charging valve (or other valve on the evaporator **below** the liquid refrigerant level). In some applications use of the valve adapter may not be necessary.
- 2) Next, from the installation kit, select the ¼" **NPT access valve fitting**, ¼" **Female Flare to 3/8 Flare adapter** and the 3/8" **ODS spring-less check valve**. (PLUG THE UNUSED NPT PORT USING A ¼" PIPE PLUG FROM THE INSTALLATION KIT). Using 3/8" OD copper tubing and the above selected items plumb the Fill Line as illustrated in **Figure 1 on page 7**.
- 3) Using the *insulation material* from the installation kit, insulate the complete Fill line. Failure to properly insulate the fill line can under certain conditions result in *vapor locking* preventing gravity flow of refrigerant from the evaporator to the dehydrator.

RETURN LINE and EQUALIZATION SOLENOID VALVE

NOTE: The Refrigerant Return Line MUST be connected to a point on the evaporator ABOVE the liquid level such as the evaporator gauge stop valve. Connecting the return line to a point below the liquid level will prevent proper pressure equalization between the dehydrator shell and the evaporator impeding or preventing gravity flow of refrigerant to the dehydrator during the fill cycle.

- 1) Install the moisture indicator between the outlet port (bottom of tank) of the dehydrator and the “Tee” attached to the equalization Solenoid. Now install the Strainer between the other side of the equalization solenoid “Tee” and the gauge stop valve (or appropriate place).

NOTE: The moisture indicating sight glass **MUST** be installed so that it is centered on line with the top of the dehydrator dryer shell as illustrated in Figure 1. This will facilitate determination of proper dehydrator filling.

LEAK TESTING

- 1) Utilizing the Access Valve fitting (installed in the charging valve adapter) pressurize the Dehydrator to 30 psi with nitrogen and check for leaks at all brazed joints and flare fittings. Then utilizing the schrader valve on the removable flange plate evacuate the dehydrator.

FILTER CORE INSTALLATION

- 1) Install filter-drier cores per standard procedure.

You will notice that flow through the drier cores is opposite that of a typical replaceable core filter-drier. The drier-cores work equally well in either direction. If you refer to Parker’s Instruction Sheet – 014062-00 (found inside the dehydrator shell) you will see that the *inlet* and *outlet* connections are interchangeable in certain applications. The *Continuous Refrigerant Dehydrator* is one of these applications. This does not affect filter core installation instructions. ***Install the filter-drier cores as you would in a standard replaceable core filter-drier.***

However, because the flow direction is reversed the 120-mesh ***inlet strainer screen*** is now at the outlet end of the Dehydrator shell and thus for all practical purposes useless. Therefore, a 3/8” flare ***inline strainer*** is provided in the installation kit for installation in the refrigerant return line as illustrated in *Figure 1*. The purpose of the inline strainer is to do what the 120-mesh screen would ordinarily have done and that is, trap and collect any particles that might have rubbed off the drier cores during installation.

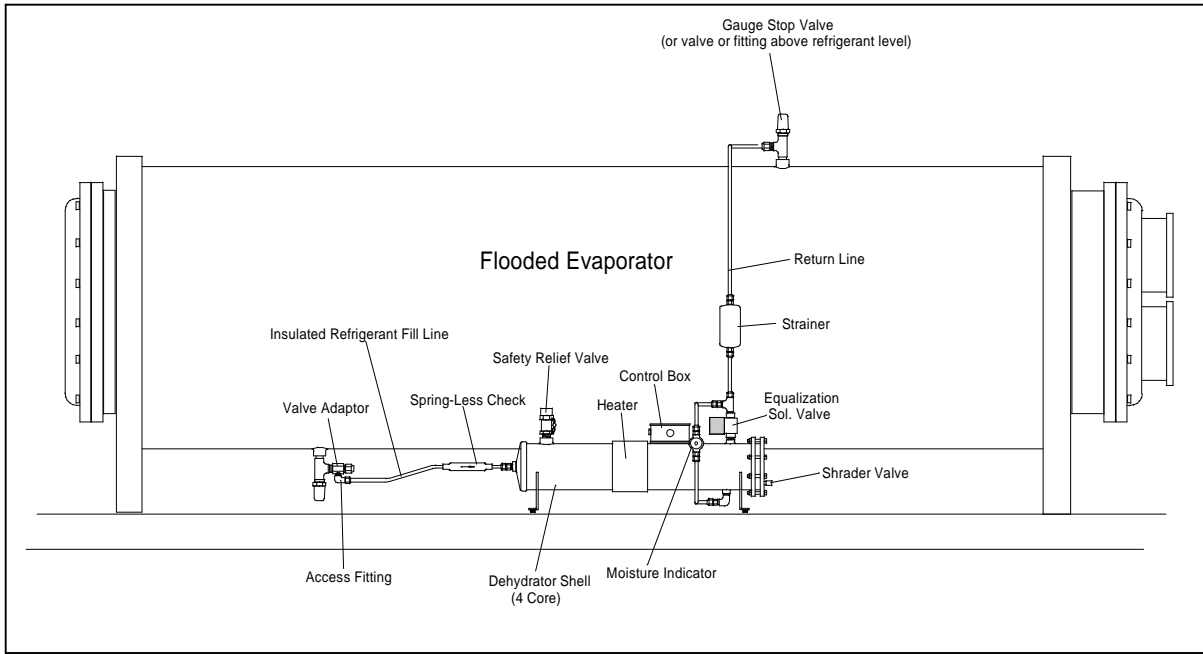

Figure 1

ELECTRICAL CONNECTION

WARNINGS: Be sure to open and lockout all appropriate electrical disconnects to prevent possible injury or death caused by electrical shock during installation.

NOTE: Use Class 1, 14 AWG copper wire and metal conduit. All field wiring must comply with applicable NEC and Local electrical codes.

ELECTRICAL HOOK-UP and POWER REQUIREMENT

120 VAC, 50/60 Hz, 1-Phase 15 Amp Fused Circuit.
Actual current draw approximately 4 amps.

NOTE: The *Continuous Refrigerant Dehydrator* is designed to dehydrate and clean the chiller's refrigerant charge continuously around the clock even when the chiller is OFF. Therefore, **for maximum effectiveness the 120 VAC supply should be from a source independent of chiller power** (otherwise shutting down the chiller may shut down the Dehydrator thereby cutting down on its maximum efficiency).

- 1) Refer to Wiring Schematic (See Figure 2 on page 10). Using a ¼" push-on terminal connect 120 Line to Power switch SW-1.
- 2) Using a ¼" push-on terminal connect the Neutral Line to the piggyback connector connected to terminal 3 on the Cycle Timer

START-UP

- 1) Open all chiller valves to the Dehydrator.
- 2) Apply power to Dehydrator and turn the ON-OFF switch to the ON position.
- 3) The *Equalization Solenoid Valve* should now be **energized** (opened). Monitor the Return Line moisture indicator to verify proper filling of the dehydrator. It may take 15 to 20 minutes before a level appears in the glass.
- 4) After 20 minutes, whether or not a level is visible in the sight glass, the equalization solenoid valve will **de-energize** (close) and the heater will **energize**. The heater will remain energized for 10 minutes. During this time the refrigerant in the dehydrator will become pressurized and pushed back to the evaporator through the Return Line.

NOTE: In most instances the Dehydrator may be emptied of refrigerant before expiration of the 10 minute timed period. This is normal.

- 5) At the conclusion of the refrigerant return cycle the next Fill cycle is initiated.

MAINTENANCE

Periodically check the return line *moisture indicator*. Whenever the moisture indicator indicates wet replace all **four Z-48 Filter drier cores**.

NOTE: For maximum dehydration efficiency *Redi Controls* recommends using only **Parker Z-48 Super Hi Moisture Capacity Cores**. The Parker Z-48 Core has **60 percent more moisture absorbing capacity** than the Sporlan RCW-48 and similar high capacity cores thus requiring less frequent replacement resulting in **substantial savings in both core replacement and labor cost**.

For even **MORE SAVINGS** you can order your **Parker Z-48 cores** direct from Redi Controls at **20% discount** (in case lot). To order and save use our toll free number... **1-800-626-8640**.

Replaceable Drier Cores

Comparison Chart

(Data based on ARI capacity for R-22 @ 75°F liquid temp.)

	Parker		Sporlan		Alco	
Application	Model	Water Cap.	Model	Water Cap.	Model	Water Cap.
<i>Super Hi Moisture</i>	Z-48 (POE compatible - Hi moisture, acid, sludge & particulate removal)	1659	RCW-48 (POE compatible)	988	UK-48 (POE compatible)	1181
<i>High Capacity</i>	PCX-48 Gold (POE compatible - Hi moisture, acid, Oil Paste)	697	N/A	N/A	H-48	597
<i>Standard Capacity</i>	PCK-48 (Moisture, varnishes, sludge, & acid)	549	RC4864	347	D48	363
<i>Burnout / Acid & Wax Removal</i>	PCK-48HH (Acids, water, solids & sludge)	474	RC4864HH	307	W-48	335

The Parker PCX-48 core has been reported & verified by Refrigerator Service Mechanics to be the ONLY core to pick-up the Oil Paste in POE often mistaken for Wax.

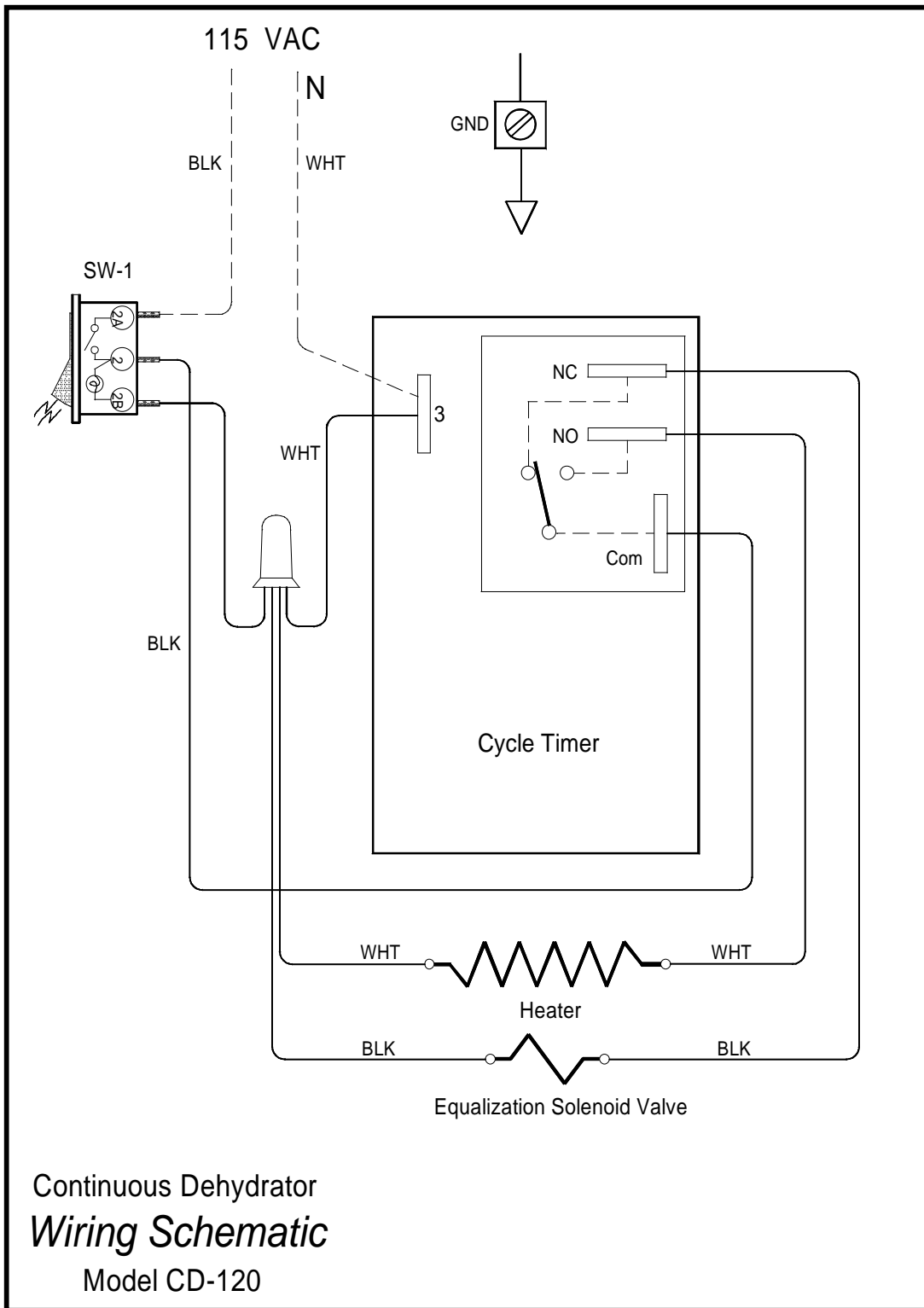

Figure 2

REDI CONTROLS, INC. Equipment Warranty

Subject to the terms below, REDI CONTROLS will, within one year after date of purchase, repair any REDI CONTROLS' product being used by the original purchaser, which is defective due to faulty materials or workmanship. REDI CONTROLS has the right to repair or replace a defective part or replace the entire product.

To file a Warranty claim on any system or component, return the defective unit to the address below, or other location as REDI CONTROLS directs, freight prepaid.

This Warranty does not apply to or cover:

Damages beyond REDI CONTROLS' control.

Malfunctions that result from failure to properly install, operate or maintain a product in accordance with instructions provided by REDI CONTROLS.

Failures of equipment due to abuse, accident or negligence.

Damages from, or part failures due to equipment not being installed per REDI CONTROLS' instructions, per applicable codes or ordinances, or in accordance with good trade practices.

Labor or other charges incurred in removing or reinstalling any REDI CONTROLS product or part.

Damages resulting from use of a REDI CONTROLS product for any purpose other than for which it was designed and manufactured.

Any implied warranty of merchantability or fitness for any particular purpose, occurring after the Warranty Period.

Loss of use, loss of time, inconvenience, rental for substitute products, loss of business, loss of income, or any other consequential damages resulting from use or failure of any REDI CONTROLS product.

Inquiries to: REDI CONTROLS at 755 E. Main Street,
Greenwood, Indiana, 46143

REDI CONTROLS, INC.
(317) 865-4130
e-mail us at: redi@redicontrols.com

Check our Web Site at: www.RediControls.com