

Redi Controls, Inc.

Installation Operation & Maintenance Manual

File Literature No. 1027-02

RuptureSeal™

Model

NRS-3

COMBINATION...
Non-Fragmenting
Metal
Rupture Disk &
Backup
Relief Valve...



Patent Number 5,644,930

...for use on Low Pressure Centrifugal Chillers

R-11

R-113

R-123

*Manufactured in accordance with
ASHRAE Guideline 3-1990 Sec. 4.6
Flow Tested per ASME Standards*

Revised Technically as of May 1, 1995
This Copy was Printed as of February 4, 2005

© 1995 INDIANAPOLIS SPECIALTY VALVE, INC., IND'PLS, IN
This product is marketed and sold by Redi Controls, Inc.,
under license from Indianapolis Specialty Valve, Inc.

Table of Contents

	Page
GENERAL INFORMATION	4
Specifications	5
General Overview	5
Installation Kit	6
Field Provided Items	6
INSTALLATION	7
Figure 1. - <i>Typical Installation</i>	8
Figure 2 - <i>Vent Pipe Hook-up</i>	8
Figure 3 - <i>Cutaway View</i>	9
Figure 4 - <i>Pressure Gauge</i>	9
Figure 5 - <i>Optional Alarm</i>	9
Figure 6 - <i>Double Check Pressure Equalizing Valve</i>	10
Figure 7 - <i>Supplemental Support</i>	10
Figure 8 - <i>Special Piping for R-123 Systems</i>	10
Leak Testing Procedure	11
Annual Maintenance	11
Following a Rupture	13
Servicing and Replacing O-Rings	13
Appendix "A" (<i>Table for determining size of vessel NRS-3 can be installed on</i>)	14
Appendix "B" (<i>Excerpt from Guideline BSR/ASHRAE 15-1992R</i>)	15
Appendix "C" (<i>Non-typical installations and their effect on valve's operation</i>).	16
Parts List	17
Warranty	Back Page

GENERAL INFORMATION

**YOU ARE URGED TO READ THIS MANUAL COMPLETELY BEFORE
INSTALLING THIS VALVE**

Upon Receiving Your Unit

Inspect the unit for possible damage caused during shipping. **Contact Equipment Servicing before attempting to use a damaged unit.** (800) 626-8640 or (317) 865-4130.

Warnings and Cautions

NOTE: *Warnings and Cautions appear in highlighted boxes as illustrated below at appropriate points throughout this manual. Give special attention to these items.*

Warnings: are provided to alert you to potential hazards that could result in serious personal injury and damage to your equipment. Warnings may appear in this manual or on the equipment. Heed all Warnings.

Cautions: are designed to alert you to situations that may result in damage to your equipment.

Personal safety and the proper operation of your equipment require strict observance of these precautions.

**THIS VALVE SHOULD BE INSTALLED ONLY BY
QUALIFIED PERSONNEL**

Warning: Certain servicing procedures may expose you to harmful materials and dangerous conditions. To minimize the possibility of injury, follow safety procedures and instructions described in this manual, on product labels and in material safety data sheets provided.

NOTE: *The manufacturer has a continuous equipment improvement policy and reserves the right to change specifications and design of its products without notice.*

Specifications

- Flow capacity: 2128 SCFM
 - Set pressure: 15 psig
 - Refrigerant compatibility: R-11, R-113 & R-123
 - Weight: 37 pounds
 - Dimensions: installed length 14 inches, height 17 inches, width 8 inches
 - Calibration is factory sealed to prevent inadvertent tampering or dis-assembly
-

General Overview

The **RuptureSeal™** non-fragmenting rupture disk backup relief valve, is designed specifically for application on low pressure (15 psi or below) centrifugal chillers.

The primary function of the **RuptureSeal™** is to minimize refrigerant loss to the atmosphere in the event of a burst rupture disk. The **RuptureSeal™** accomplishes this vital function by automatically closing off the vent path, thus re-sealing the chiller once pressure returns to normal. In the event of a burst rupture disk, the **RuptureSeal™** also serves as the interim primary relief.

NOTE: *The RuptureSeal™ model number designates the size of the non-fragmenting metal rupture disk incorporated in it's design. (i.e., the "NRS-3" has a 3" non-fragmenting metal rupture disk and is to be used on a low pressure centrifugal chiller with a 3" relief.) **The NRS-3 has a flow capacity of 2128 SCFM, and since the NRS-3 has been flow rated with the rupture disc as part of the valve , the rated flow capacity of the valve (2128 SCFM) does not have to be de-rated. Before installing the NRS-3 valve, the installer must determine if the flow capacity is adequate for that chiller.** INCLUDED FOR YOUR CONVENIENCE AS Appendix "A" IS A TABLE OF VARIOUS VESSEL DIMENSIONS COVERED BY THE MODEL NRS-3 RuptureSeal™ based on computations using the formula provided by the Guideline BSR/ASHRAE 15-1992R. Appendix "B" of this manual contains an excerpt from the Guideline BSR/ASHRAE 15-1992R which can be used to determine the minimum flow capacity requirement for a pressure-relief device as applied to a low pressure centrifugal chiller.*

Installation Kit

Kit includes:

NOTE:

See Figures 3 on Page 9 and 6 on Page 10 for location of parts on assembled unit.

One (1) Pre-assembled NRS-3 **RuptureSeal™** which includes:

- One non-fragmenting metal rupture disk 15 (PSI)
- One flange gasket
- Four (4) flange bolts with nuts
- One (1) Tell-Tale pressure gauge 30" Hg - 0-30 psig
- One (1) Double Check Pressure Equalizing valve with Filter/Vent
- One (1) Installation Operation & Maintenance Manual

Warning: Removal of the wire and seal (16) from locking screws will compromise valve calibration and void the warranty! If service to the valve assembly effecting calibration is required, it must be returned to manufacturer for service.

Field Provided Items

Items to be supplied by installer:
(see Figure 2 on page 8)

- Pipe and flexible metal connection **(33)**
- Pipe Fittings
- Drip leg **(31)** with Drain Port
- ¼" line **(37)** to connect Valve Body water drain hole **(24)** to Drip Leg **(31)**
- A three inch (3") Female NPT Pipe Union **(12)**
(see Figure 2 on page 8)
- Supplemental support materials (when applicable)

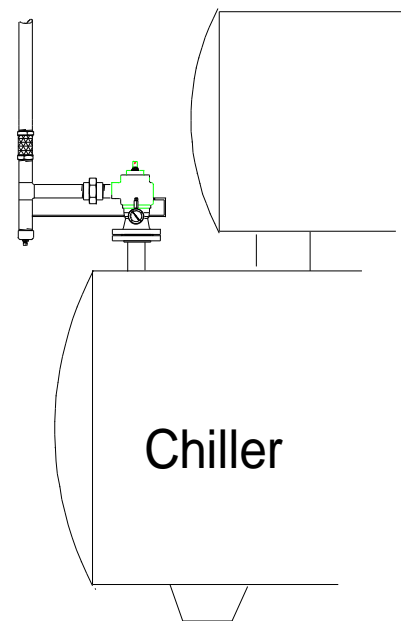

Typical Installation

INSTALLATION

Installation of the **RuptureSeal™** should be performed only by qualified personnel. The following installation instructions should be thoroughly read and understood before attempting installation.

Alterations to the existing rupture disk vent piping and removal of existing carbon rupture disk are necessary to install the NRS Series **RuptureSeal™** valve. The installer should determine in advance what tools and materials will be needed.

Caution: Federal Refrigerant Recycling Regulations require that the chiller, during servicing, be either completely evacuated or pressurized to atmospheric pressure (0 psig) prior to opening the refrigerant circuit to the atmosphere. Failure to comply, or using means other than heat to elevate refrigerant pressure, violates Section 608 of the Clean Air act.

Warning: Discharge Vent Line piping must comply with all applicable codes and standards. Refer to ASHRAE Standard 15-1992 and equipment manufacturer's installation manual for rupture disk and relief valve vent line piping instructions.

Warning: DO NOT install an NRS-3 RuptureSeal™ on a 2" outlet relief. Likewise, DO NOT install an NRS-2 RuptureSeal™ on a 3" outlet relief. The rated flow capacities of the RuptureSeal™ relief valve apply only when the appropriate Model is used on an appropriate sized outlet relief.

Installation Steps 1 thru 7

Warning: NEVER attempt to install a damaged valve!

Caution: The reverse buckling rupture disk cassette comes installed in the relief valve inlet flange and is retained by a plastic shipping protector. When removing the plastic protector, be extremely careful not to let the disk cassette fall out. It is extremely important to understand that the rupture disk membrane is very fragile and must not be touched. Any dents or irregularities in the crowned area of the disk shall be cause for rejection. If damaged, the disk will not function as specified.

INSTALLATION (continued)

1. Determine the best mounting arrangement for the **RuptureSeal™** in relation to the chiller's existing relief outlet and vent piping. Also determine if supplemental support for the valve will be necessary (see Figure 7 on page 10). Note that the valve body can be rotated 360° to orient the outlet to the vent pipe. To rotate the valve body, loosen (do not remove) the five (5) valve body locking screws (see Appendix "C" on page 16 for illustrations). Once in position, re-tighten (do not over tighten) the five (5) valve body locking screws. (See Figure 3 on page 9 for location of locking screws.)
2. The **RuptureSeal™** "valve" can be mounted in either a vertical or horizontal position (see **Figure 1 - Typical Installation**). The NRS-3 can not be mounted upside down.

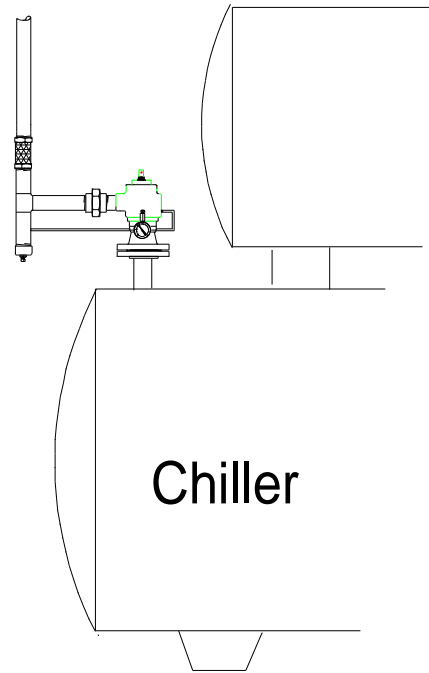

Figure 1
Typical Installation
(See Appendix "C" for other illustrations)

NOTE: Regardless of NRS-3's mounting position, the Double Check Pressure Equalizing Valve (22) **MUST** be mounted vertically with the filter/vent (34) pointing up (↕).

3. Determine how much of the existing rupture disk vent piping will have to be removed to accommodate the **RuptureSeal™**. Cut out and remove this section of piping.
4. It is recommended that a flexible metal connection (33) and a 3" NPT union (12) be installed as illustrated in Figure 2.
5. The installer shall determine the best way to plumb the discharge vent line using figure 2 as a piping guide.
6. Insert the Flange Gasket between the Valve Inlet Flange and the existing chiller rupture disk flange.
7. Using the four flange bolts provided, mount the valve to the chiller rupture disk flange. Tighten bolts sufficiently to assure proper leak free seal.

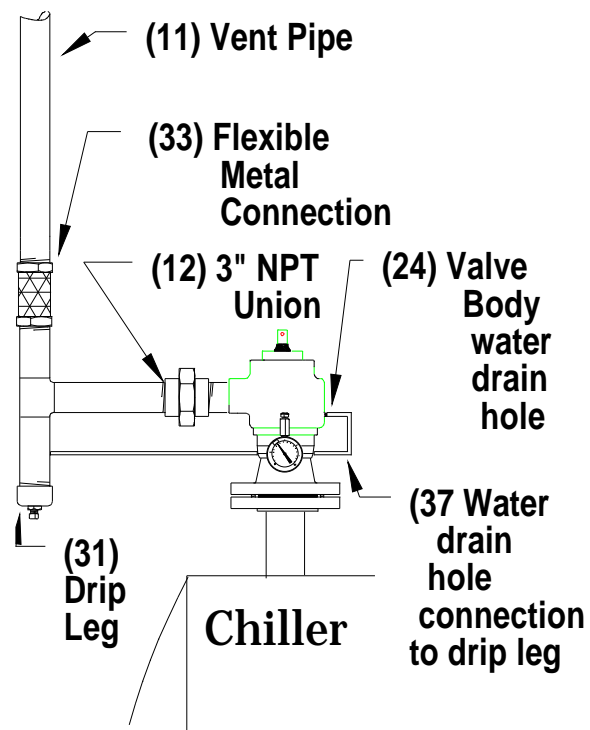

Figure 2.
Vent Pipe Hook-up

INSTALLATION (continued)

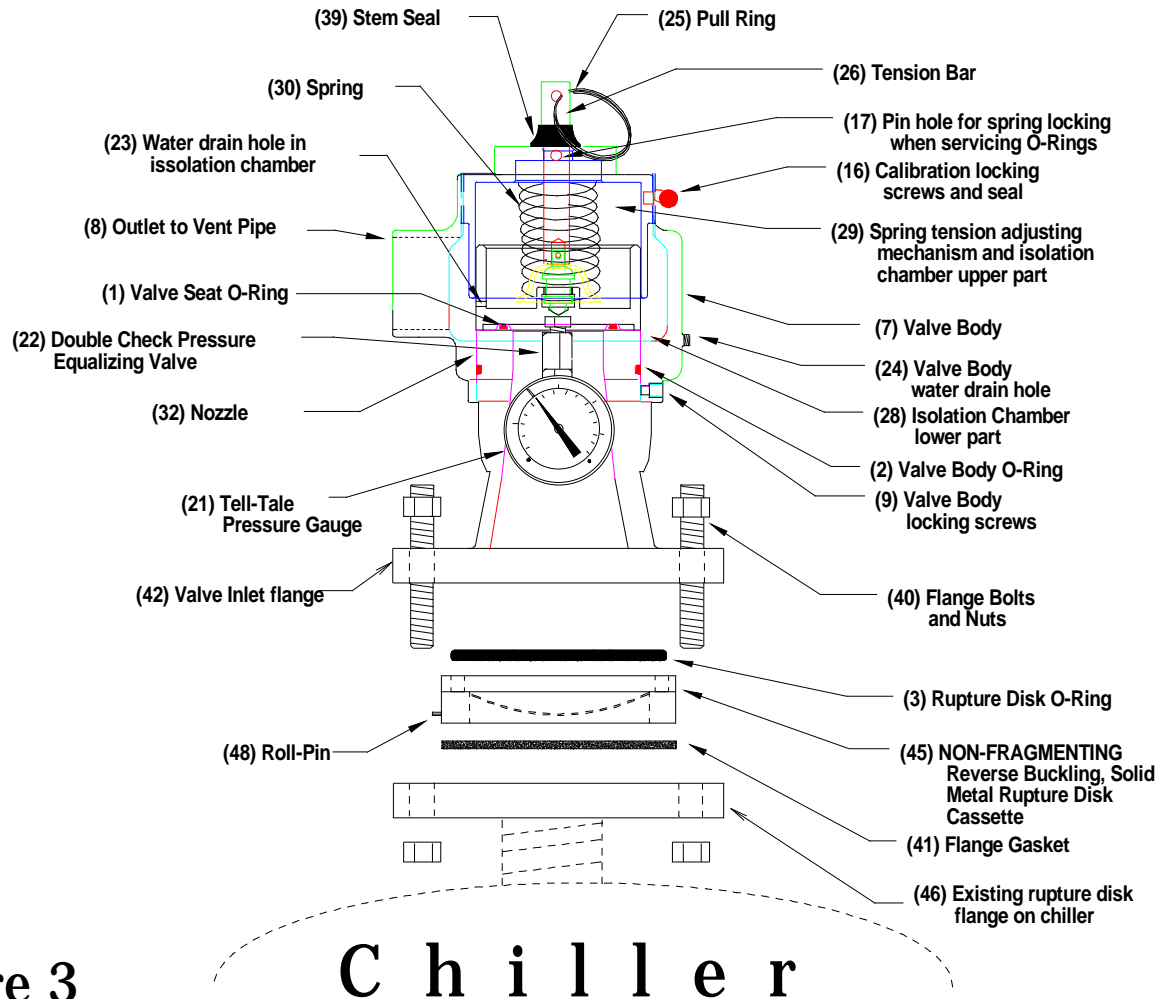

Figure 3
Cutaway View

Pressure Gauge

The Tell-Tale pressure gauge (21), located between the rupture disk and the valve seat, is provided to indicate when a rupture disk has burst or is seeping. A pressure or vacuum reading other than “0” psig indicates a problem with the rupture disk.

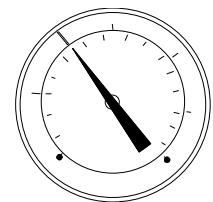

Figure 4
Tell-Tale
Pressure Gauge

Auxiliary Alarm

An optional **RuptureAlarm™** is available to supplement the pressure gauge. **(IT IS HIGHLY RECOMMENDED.)** The Alarm will signal if the rupture disk ruptures. See Appendix “C” on page 16 for alarm mounting location. Contact equipment servicing for information on the optional **RuptureAlarm™**.

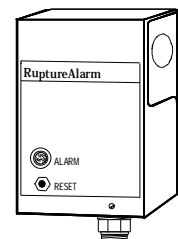

Figure 5
Optional Alarm

Double Check Pressure Equalizing Valve

The double check pressure equalizing valve (22) is provided to prevent pressure build-up between the **RuptureSeal™** valve seat and the rupture disk. This special double check pressure equalizing valve allows low pressure build-up to bleed-off, but seals itself under pressure or vacuum.

Warning: DO NOT obstruct outlet of the Double Check Pressure Equalizing Valve.

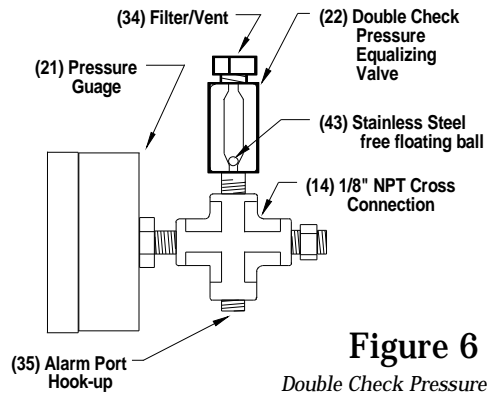

Figure 6
Double Check Pressure Equalizing Valve

NOTE: Regardless of NRS-3's position, the Double Check Pressure Equalizing Valve (22) MUST be mounted vertically with the filter/vent (34) pointing up (↕).

Supplemental Mounting Support

If the **RuptureSeal™** valve is to be mounted in the horizontal position, it is recommended that some type of supplemental support be provided to relieve any stress the valve may put on the chiller's relief stub (see Figure 7). The installer shall determine the best way to provide such supplemental support.

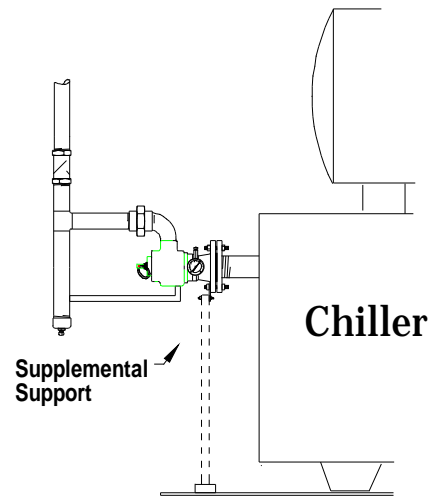

Figure 7 - Supplemental Support

Chillers Utilizing R-123 (special piping instructions)

When installing a **RuptureSeal™** valve on a chiller utilizing R-123 refrigerant, it is suggested that the output of the Double Check Pressure Equalizing Valve (22) be teed into the water drain line (37) (see Figure 8). This will prevent seepage of R-123 refrigerant into the occupied space in the event of a failure of the rupture disk.

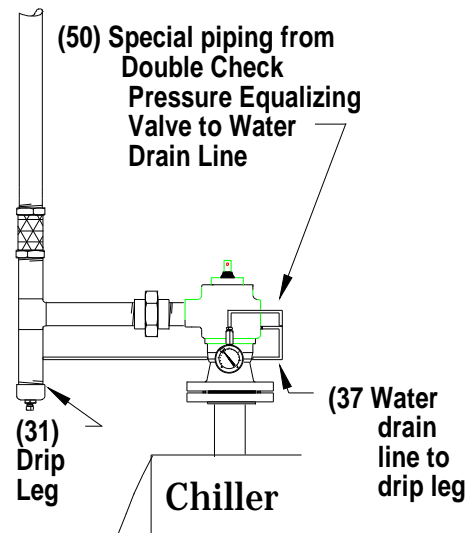

Figure 8 - Special Piping for R-123 Systems

Leak Testing Procedure

Caution: DO NOT use this procedure if chiller pressure is lower than 15" Hg. Otherwise, the rupture disk may implode into the chiller!

1. Remove pipe plug (or optional Rupture Alarm™ if used) from alarm port (35) of Connector (14).
2. Utilizing a 1/8" NPT x 1/4" Flair half union, connect a refrigeration manifold set (low side hose) to the alarm port (35) of Cross Connector (14).
3. Carefully raise the pressure level to **NO MORE THAN 5 PSI MAXIMUM**, and test for leaks using standard leak testing procedures.

Warning: During testing, to maintain pressure at such a low psi, you may have to remove the filter/vent (34) and hold your finger over the outlet of the Double Check Pressure Equalizing Valve. DO NOT install a plug in outlet of the Double Check Pressure Equalizing Valve. Failure to remove plug after leak test could create a serious safety hazard.

4. At conclusion of Leak test procedure, release pressure and remove hose and fitting. Reconnect alarm tube or re-install pipe plug in alarm port (35) and secure tightly.

Annual Maintenance

Warning: DO NOT TAMPER WITH WIRE AND LEAD SEAL DURING SERVICING! Removal of wire and lead seal will compromise pressure relief calibration and void the warranty. If service to the valve assembly effecting calibration is required, it must be returned to manufacturer for service. ANNUAL SERVICING DOES NOT AFFECT CALIBRATION.

1. **BEFORE SERVICING THE VALVE**, pull up pull ring (25) and insert a pin in 2nd hole (17) of tension bar (26). This will protect the valve seat O-Ring and keep the valve body from popping up when valve body locking screws are removed.
2. After pinning the spring tension bar, break vent pipe union (12) (see Figure 2 on page 8).
3. Next, remove the five (5) valve body locking screws (9), and lift valve body (7) from the valve nozzle (32).
4. Inspect valve seat O-Ring (1) and valve body O-Ring (2). If there are any visible signs of wear or excessive compression set, replace the O-Rings. Lightly oil the valve seat O-Ring to facilitate installation into the dove-tail O-Ring groove.

O-Ring type & sizes are: Valve seat O-Ring (1) is a Parker - #2-146-V747-70
Valve body O-Ring (2) is a Parker - #2-241-N674-70

Annual Maintenance (*continued*)

5. Inspect water drain hole (24) in valve body (7) to make sure it can drain properly.
6. Lightly oil valve body O-Ring (2) and reinstall valve body (7) on valve nozzle (32).
7. Make sure the five (5) valve body locking screws (9) are screwed completely in against the valve nozzle (32), thereby locking the valve body in the correct position. (The screws must be screwed in until they are firmly secured, but do not over tighten.)
8. Re-connect the 3" NPT union (12). Check drip leg (31) for proper drainage.
9. Lift pull ring (25), remove pin and gently allow valve to close.

NOTE: *Be sure the Double Check Pressure Equalizing Valve is pointing up and is unobstructed. The Double Check Pressure Equalizing Valve will function correctly only when in the vertical position. The double check pressure equalizing valve (22) is provided to prevent a pressure build-up between the RuptureSeal™ valve seat and the rupture disk.*

10. Inspect the double check pressure equalizing valve filter/vent (34). Be sure it is clean and unobstructed.

Warning: DO NOT obstruct Filter/vent outlet on the Double Check Pressure Equalizing Valve (22).

11. Inspect tell-tale pressure gauge (21) and verify for proper operation.
12. Finally, test for leaks (see page 11 for leak testing procedure).

NOTE: *During the annual maintenance procedure, it is normally not necessary, unless there is an obvious leak, to service the non-fragmenting metal rupture disk or its O-rings.*

Following a Rupture

Perform “Annual” maintenance procedures (steps 1 thru 12 - pages 11 and 12).

When it becomes necessary to replace the rupture disk, the appropriate instructions will accompany the replacement disk. Therefore, only brief replacement instructions are given here. The non-fragmenting rupture disk cassette is fragile and requires careful handling, therefore this part of the valve should only be serviced after a rupture or if the disk is determined to be defective or leaking..

1. Remove entire **RuptureSeal™** valve from the chiller. (Be careful to prevent the rupture disk cassette from falling out of the valve.)
2. Remove spent rupture disk cassette and install new replacement cassette per installation instructions (contact equipment servicing).
3. Install new cassette O-Ring - Parker O-ring #2-241-N674-70 - furnished with replacement rupture disk cassette.
4. Install new flange gasket (furnished with replacement rupture disk cassette) between disk cassette and chiller flange. Reinstall valve and tighten flange bolts sufficiently to assure proper seal.

Servicing and Replacing O-Rings

For servicing Valve Body O-rings 1 and 2, see procedures for annual maintenance starting on page 11.

For servicing Disk Cassette O-ring 3, see procedures for servicing the valve following a rupture above.

Appendix “A”

RuptureSeal™ Model NRS-3 (2128 SCFM)

for

R-11

R-113

R-123

Purpose of Table

This table will assist the installer in determining the maximum size of chiller vessel (evaporator) with a three inch (3”) relief port that can be fitted with the Model NRS-3 RuptureSeal™ valve. **(NOTE: Because the RuptureSeal™ NRS-3 has been flow rated with the rupture disk as an integral part of the valve, the flow capacity does not have to be derated when installed.**

How to use Table

Obtain the **diameter** and **length** of the chiller vessel (evaporator).

Refer to the table below and locate the “**Diameter**” measurement that equals the diameter of the chiller vessel (evaporator). The measurement to the immediate right of the evaporator’s diameter indicates the “**Maximum Length**” of the chiller vessel (evaporator) that the Model NRS-3 RuptureSeal™ valve can be installed on.

Evaporator Diameter FEET & INCHES	Maximum Evaporator Length	Evaporator Diameter FEET & INCHES	Maximum Evaporator Length	Vessel Diameter FEET & INCHES	Maximum Evaporator Length
4’ 0” or less	40’ 0”	4’ 8”	34’ 3”	5’ 4”	30’ 0”
4’ 1”	39’ 2”	4’ 9”	33’ 8”	5’ 5”	29’ 6”
4’ 2”	38’ 4”	4’ 10”	33’ 1”	5’ 6”	29’ 0”
4’ 3”	37’ 7”	4’ 11”	32’ 6”	5’ 7”	28’ 8”
4’ 4”	36’ 11”	5’ 0”	32’ 0”	5’ 8”	28’ 2”
4’ 5”	36’ 2”	5’ 1”	31’ 6”	5’ 9”	27’ 9”
4’ 6”	35’ 6”	5’ 2”	30’ 11”	5’ 10”	27’ 5”
4’ 7”	34’ 11”	5’ 3”	30’ 5”	5’ 11”	27’ 0”
				6’ 0”	26’ 8”

NOTE: Calculations are based on BSR/ASHRAE Standard 15-1992R - Section 9.7.5

Warning: The above calculations are NOT APPLICABLE if combustible materials are used within twenty (20’) feet of the chiller vessel (see BSR/ASHRAE 15-1992R).

Appendix “B”

Excerpt from Guideline BSR/ASHRAE 15-1992R

9.7.5 The minimum required discharge capacity of the pressure-relief device or fusible plug for each pressure vessel shall be determined by the following:

$$C = f DL$$

WHERE:

- C** = minimum required discharge capacity of the relief device in **POUNDS OF AIR PER MINUTE (KG/S),***
(*emphasis and asterisk added*)
- D** = outside diameter of vessel in feet (m),
- L** = length of vessel in feet (m),
- f** = factor dependent upon type of refrigerant.

Note: When combustible materials are used within 20 feet (6.1 m) of a pressure vessel, multiply the value of *f* by 2.5.

REFRIGERANT	VALUE OF <i>f</i>
<i>When used on the lowside of a limited-charge cascade system:</i>	
R-170, R-744, R-1150	1.0 (0.082)
R-13, R-13B1, R-503	2.0 (0.163)
R-14	2.5 (0.203)
<i>Other applications:</i>	
R-717	0.5 (0.041)
R-11, R-40, R-113, R-123, R-142b, R-152a, R-290, R-600, R-600a, R-611, R-764	1.0 (0.082)
R-12, R-22, R-114, R-134a, R-C318, R-500, R-1270	1.6 (0.163)
R-115, R-502	2.5 (0.203)

When one pressure-relief device or fusible plug is used to protect more than one pressure vessel, the required capacity shall be the sum of the capacities required for each pressure vessel.

*** Note:** To convert from pounds of air per minute to SCFM, multiply by 13.3.

Appendix “C”

The NRS-series valves can be mounted in various positions (**other than upside down!**). (The following illustrations depict some of the various mounting positions.

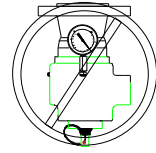

Vertical Mounting

Mounting variations from simply rotating the valve body (7): The drawings below illustrate the typical vertical mounting positions for the NRS-series valves, with variations obtain by rotating the valve body. Rotate-1 is the typical installation position of the valve body. Rotate-2 illustrates a mounting where the valve body has been rotated 90° clockwise. Rotate-3 illustrates a mounting where the valve body has been rotated 180° clockwise, and Rotate-4 illustrates a mounting where the valve body has been rotated 270° clockwise.

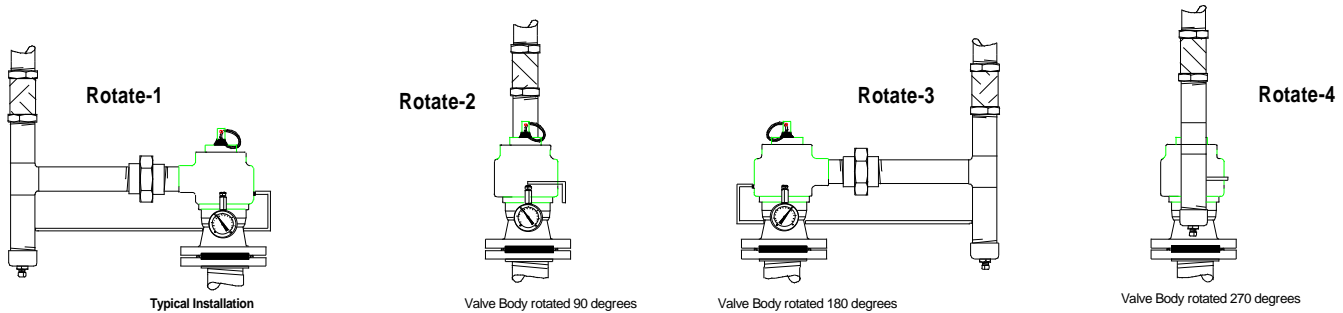

Horizontal Mounting

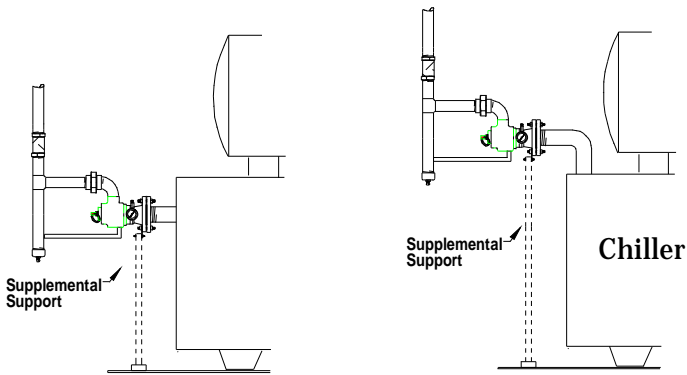

NOTE: If the NRS-3 RuptureSeal™ valve is mounted in the horizontal position, its opening pressure will be lower than the factory setting of 15 psi (the valve is calibrated by the manufacturer for vertical mounting). This will not negatively effect the valve’s flow capacity. The valve’s opening point will be approximately 1/2 psi lower than its normal set point of 15 psig, however the functioning of the RuptureSeal™ will not be significantly effected.

RuptureAlarm™ Mounting

Caution: Regardless of mounting position of the NRS-3, the Double Check Pressure Equalizing Valve (22) **MUST** be mounted in a vertical position with the filter/vent (34) pointing up (↕). Mounting the double check pressure equalizing valve (22) vertically may require additional fittings.

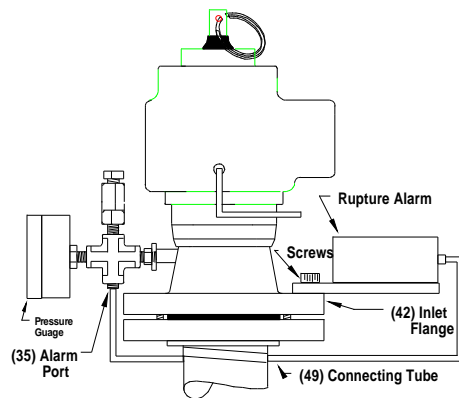

Illustration of RuptureAlarm™ mounting

Parts List for NRS-3

<u>Name of Part</u>	<u>Part Number</u>
1. 30" Hg - 0 - 30 psi GAUGE	RS-G1
2. Double Check Pressure Equalizing Valve	RS-DCV1
3. Non-fragmenting metal rupture disk (15 psi)	NRS-3-15 psi
4. Flange Gasket	NRS-3 GAS
5. Four (4) flange bolts and nuts	NRS-BOLTS

O-Ring type & sizes:

Valve seat O-Ring	Parker - #2-146-V747-70
Valve body O-Ring	Parker - #2-241-N674-70
Rupture disk cassette O-ring	Parker - #2-241-N674-70

All other parts of the valve are internal and cannot be replaced in the field. If any internal part needs to be replaced, the **RuptureSeal™** must be returned to Equipment Servicing for repairs.

Redi Controls, Inc.

Equipment Warranty

Subject to the terms below, **REDI CONTROLS** will, within one year after date of purchase, repair any **REDI CONTROLS**' product being used by the original purchaser, which is defective due to faulty materials or workmanship. **REDI CONTROLS** has the right to repair or replace a defective part or replace the entire product.

To file a Warranty claim on any system or component, return the defective unit to the address below, or other location as **REDI CONTROLS** directs, freight prepaid.

This Warranty does not apply to or cover:

- Damages beyond **REDI CONTROLS**' control.
- Malfunctions that result from failure to properly install, operate or maintain a product in accordance with instructions provided by **REDI CONTROLS**.
- Failures of equipment due to abuse, accident or negligence.
- Damages from, or part failures due to equipment not being installed per **REDI CONTROLS**' instructions, per applicable codes or ordinances, or in accordance with good trade practices.
- Labor or other charges incurred in removing or reinstalling any **REDI CONTROLS** product or part.
- Damages resulting from use of a **REDI CONTROLS** product for any purpose other than for which it was designed and manufactured.
- Any implied warranty of merchantability or fitness for any particular purpose, occurring after the Warranty Period.
- Loss of use, loss of time, inconvenience, rental for substitute products, loss of business, loss of income, or any other consequential damages resulting from use or failure of any **REDI CONTROLS** product.

Send inquiries to: **REDI CONTROLS** at 755 E. Main Street, Greenwood, Indiana, 46143

REDI CONTROLS, INC.

(317) 865-4130